

Safe Turning Procedures for School Bus Drivers

Reference Guide and Test

Produced by Video Communications

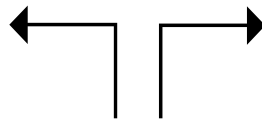
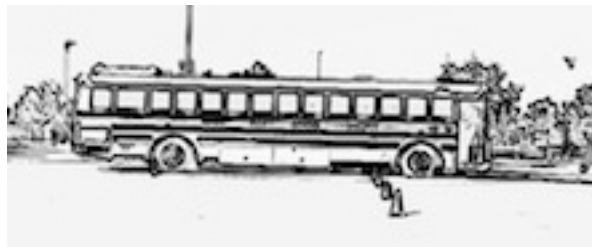

Introduction

There are several problematic situations that can arise when attempting to make a turn in a school bus. There are also many component parts that go into safely completing a turn in a vehicle as long and wide as a school bus. In the video, we tackle these situations and break down the steps to safely maneuver a turn in a school bus.

The Geometry of a School Bus

The most obvious reasons that turns are so difficult to make in a school bus are:

- a. The length of the bus.
- b. The width of the bus.
- c. The weight of the bus.

School buses can reach up to 45 feet in length. They could be up to 10 feet in width, and they can weigh anywhere from 10 to 14 tons. The length of a school bus causes numerous problems including:

- a. Knowing when the appropriate time is to turn the steering wheel.
- b. Using the mirrors on the bus.
- c. The space involved to complete a turn.

A school bus can reach up to 10 feet in width. Street lanes vary anywhere from 9 to 12 feet in width. This means the bus does not leave much maneuvering room within a lane.

School buses are tall, wide, and very long. That is why extreme focus should be exercised whenever engaging a turn in a school bus.

Right Turns

1. Right turns are tough to maneuver in a vehicle so tall and wide. There have been many instances of school bus drivers clipping signs, or rolling over street curbs during a right turn. In the video, we introduce Kathy DeVries, a safety supervisor at Southwest Transportation Agency. She is the host of the video. She instructs Liz Specht, a school bus driver on how to engage a proper right turn.

2. The video shows Kathy and Liz in a parking lot with some cones set up at a 90° angle, and rope running along the outside of the cones. This is meant to be a typical street corner to maneuver the bus around.

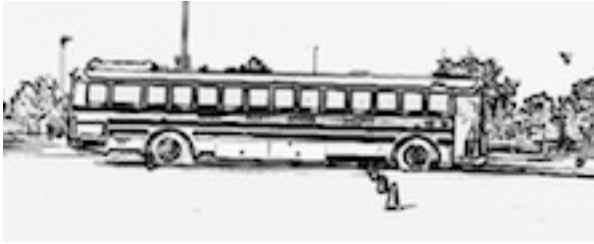

Sharp Right Turn

3. Kathy then explains to Liz that the first step when approaching a right turn, the bus driver must align the bus 18-36 inches from the right hand side of the available roadway.

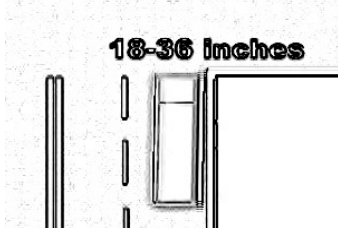

1a: The illustration is a birds eye view showing the bus 18-36 inches from the right hand side of the available roadway of a typical street.

4. In the next step, Kathy explains how to identify the ground reference for the road they will be turning onto. She also explains how to identify an imaginary line.

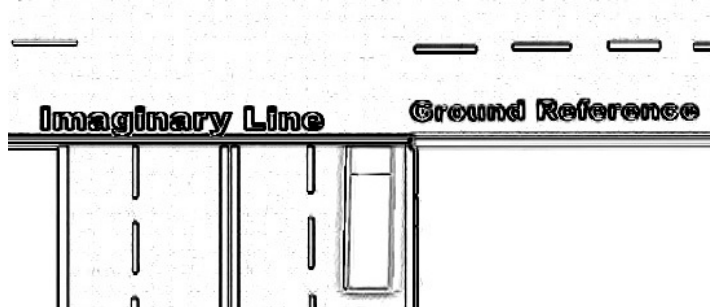

A2: The illustration shows the school bus at a sharp right turn. The ground reference is for the road the bus would be turning onto. Notice the imaginary line extends out from the ground reference.

5. Here are three key issues to remember when approaching a right turn:

- A. Align the bus 18-36 inches from the right hand side of the available roadway you are on.
- B. Identify the ground reference for the road the bus will be turning onto.
- C. And identify the imaginary line that will extend out from the ground reference.

6. The purpose of the exercise is to safely turn the corner and miss the closest problem object by 12-36 inches.

7. The video then goes on to describe what a **turning point** is. A **turning point** is a point on or in front of the bus that is used as a reference point for the driver. When the bus's turning point intersects the imaginary line, this is when a driver will full lock the steering wheel and proceed around the turn. (The turning point is used for either a right or left hand turn.) - see below

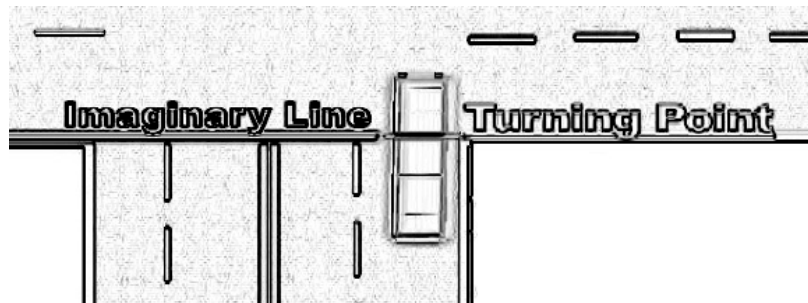

8. The turning bus should clear the closest problem object by 12-36 inches when the correct turning point has been established.

9. In the video, Kathy has Liz pull the bus up to where the vehicle reference (front bumper) meets the ground reference to the road they would be turning onto. Kathy then has Liz pull up to where she believes the imaginary line intersects the bus's turning point.

10. Liz makes several attempts to turn the bus at a sharp right turn. In order for it to be a safe turn, she must miss the cones by 12-36 inches. At one point she turns too soon, and a cone gets hit on the right side of the bus. Kathy leaves it up to Liz to try and establish the bus's turning point. After several attempts, Liz hits the mark and clears the closest problem object (cone) by 19 inches.

11. Turning points on a school bus can change depending on several factors, including:

- A. What type of bus it is.
- B. The length of the bus.
- C. The speed in which you are turning the corner.
- D. What type of corner it is.

12. Next, the video will demonstrate a rounded turn. The rounded turn has different characteristics than a sharp right turn. The turning point for a rounded turn will change even though the bus stays the same and so does the speed at which she is taking the corner.

13. Here is another important issue to consider. The video shows the bus taking up a lot of roadway when making a sharp right turn. This is the bus's turning range. Know your bus and be aware of its turning range. If the turn requires two lanes to complete the turn, be aware of your surroundings and use caution before proceeding.

14. Kathy and Liz then go to a quiet neighborhood to attempt a rounded turn in the real world. Liz's practice pays off. On her first try, she is able to maneuver the rounded turn and she misses the closest problem object (cone) by 12-36 inches.

Additional Techniques for Turning Exercises

1. **Hand positioning** is critical when making a turn in a school bus.

- A. Hands should be placed at approximately the 3 o'clock and 9 o'clock positions?
- B. Use either the hand over hand or push-pull method.
- C. Never palm the steering wheel when turning.
- D. Never let the steering wheel spin itself back into place.

2. When practicing turning maneuvers, it is recommended to **use a dead throttle start and idle through the turn.** The reason for this is to apply the same amount of speed every time around the turn. This helps the driver establish the bus's turning point.

3. Be sure your mirrors are always properly adjusted. Keep focused when using your mirrors. Because the bus is turning, the field of view is constantly changing in the mirrors and blind spots become a prime concern.

4. Next, the video shows a van occupying the right edge of the roadway that Liz will be turning onto. In this situation, the ground reference will move from the curb (edge of available roadway) to the left edge of the van. The imaginary line will extend from there and that is where Liz intersects the bus's turning point to complete the turn. By recognizing the danger posed by the problem object, the driver avoids a potential accident.

Left Turns

1. Right turns are considered more dangerous than left turns, nevertheless left turns also present challenges to the driver. It is important to understand that when making a left turn you will apply the same concepts you learned when making a right turn. A major difference, when making a left turn, is you will align your bus to the left side of the available roadway you are driving on. Also, the ground reference and imaginary line will

extend from the road you are turning onto.
(shown below)

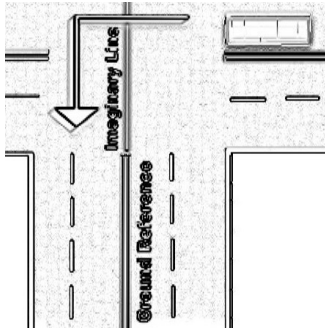

2. Kathy is the one demonstrating a left turn. She aligns the bus next to the tape that is laid out to simulate a typical street line. Kathy then pulls the bus to where she believes the ground reference and imaginary line (cones) intersect her bus's turning point. She then full locks the steering wheel to the left and idles through the turn, making sure to miss the closest problem object by 12-36 inches. She then completes the turn by realigning the bus.

3. The video then shows a birds eye view to show where the turning point meets the imaginary line. (shown below)

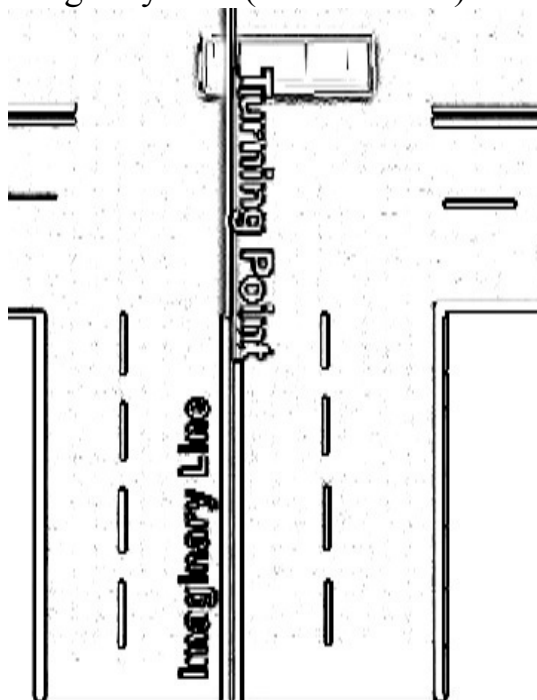

Safe Turning Procedures

Approach of a Turn

1. There are several issues to keep in mind when approaching a turn. These include:

- A: The size and weight of the bus.
- B: The condition of the road.
- C: The speed of the bus.
- D: Alertness by the driver.

2. When approaching any turn, be sure to check for traffic to the front, rear and sides of the bus. Check all mirrors and move your body to check for vehicles and pedestrians in blind spots. Also, check for traffic signals and signs.

- A. Activate the turn signal approximately 100 feet before the turn.
- B. Reduce your speed and downshift before you begin the turn.
- C. Position your bus to the correct edge of the available roadway you are on.
- D. If a stop is required at the turn, keep the front wheels straight and the brake pedal pressed. This will prevent your bus from being pushed into oncoming traffic.

3. Leave adequate space between your bus and the vehicle in front of you. If you cannot see the rear tire of the vehicle in front of you, you are too close. **Always follow state laws that apply to your school district, when making turns at traffic lights.**

Making a turn

1. Be sure to rely on your mirrors when making a turn. And always yield the right of way to pedestrians and other vehicles.

- A. Make your turn slowly and smoothly to give yourself and other drivers time to react.
- B. Never switch gears when making a turn. This causes the bus to hesitate during the turn.
- C. Be sure to watch for problem objects.
- D. Keep the turn signal on throughout the turn.

2. As previously mentioned, hand positioning is critical during a turn. Correct hand positioning and steering techniques give the driver the best possible control of the bus when making a turn.

Recovering from a turn

1. When recovering from a turn follow these safe procedures:

- A. Disengage your turn signal.
- B. Pick up speed and move into the appropriate lane.
- C. Be sure to check mirrors before switching lanes.

2. There is no such thing as an easy turn in a school bus. The bus driver has to be aware of their surroundings and alert to the fact that something can happen at any time.

Field Exercises

1. In this section of the video, Liz is up against multiple challenges when faced with a sharp right hand turn at a busy intersection. The street she will be turning onto is very narrow. There is traffic all around the bus. And a median occupies the center of the roadway.

2. Liz approaches the turn following all the safe turning procedures. She aligns her bus 18-36 inches from the right hand side of the available roadway, and uses what she learned in training to safely maneuver the turn. The over hang of the bus barely clears the center median. Liz then realigns her bus, picks up speed and moves into the appropriate lane.

3. The following turn in the same section of the video, shows a road that Liz will be turning onto. Notice the rear end of a pickup truck is protruding onto the road. She carefully navigates the bus through the turn and clears the problem object, the rear end of the vehicle, by just over 12 inches.

4. Keep in mind, whenever you are faced with a tight squeeze, it is up to you to determine whether or not it would be safe to complete the turn. Use safe judgement and err on the side of caution. If you know you cannot safely complete a turn, take another route.

Additional Safety Issues

1. Pay attention to watches, jewelry or any loose clothing you may be wearing. Do not wear items that may get snagged on the steering wheel when turning. And be sure to never palm the steering wheel while making a turn.

2. **Tail swing** of the bus is another important issue. You must be aware that the tail end of the bus is swinging outward in the opposite direction that you are turning. That is why mirror usage and perception are critical elements to practice when making turns. Drivers

must be aware of vehicles at the sides of the bus. Also, be aware of signs and other problem objects that may be hit from the tail swing of the bus. Tail swing can also make students riding the bus suffer from dizziness or car sickness. So, be sure to take all turns smooth and steadily.

3. Be sure that you pull close enough to the edge of the available roadway on approach of a turn, so vehicles don't try to squeeze by.

4. When maneuvering a turn, do not use the lane next to you and "bow out" to make your turn. Below is an illustration of the wrong way and right way to make a turn onto a narrow street.

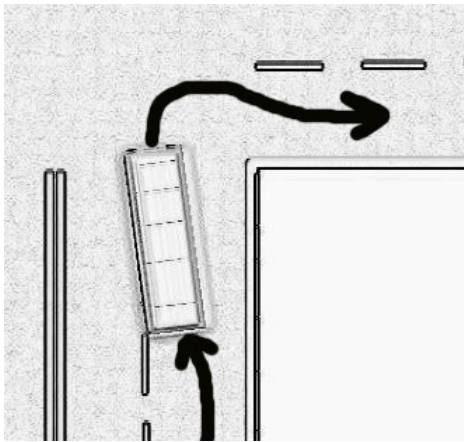

Wrong Way.

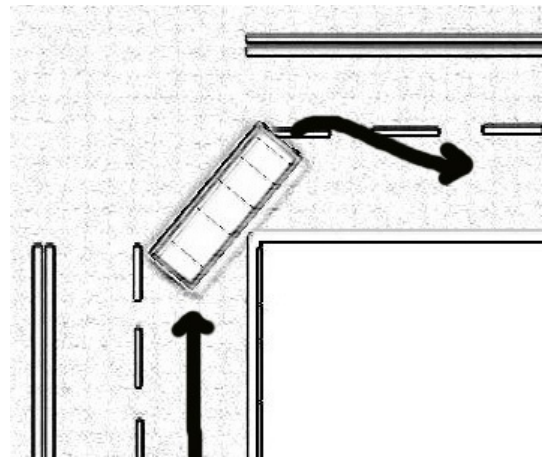

Right Way.

Summary.

Always keep in mind, the size of the vehicle you are driving. Also, school buses are expensive vehicles to purchase and maintain, so be aware of problem objects that can damage the bus during a turn. Allow for the oversize and limited maneuverability in a bus when turning.

Don't forget to check your mirrors and always use extreme caution. Do not become complacent or get lazy when making a turn. Rely on your training and focus on each facet of the turn. Constantly test yourself and practice your turning skills and judgment to properly perform these maneuvers. And remember, not only to be mindful of the precious cargo you transport everyday, but also of the vehicles and pedestrians around your bus when making a turn.

Test Questions

Circle Answers

- 1) When approaching a right turn, it is important to keep your bus parallel and _____ inches from the right side of the available roadway.
 - A. 12-36
 - B. 18-36
 - C. 12-18
 - D. None of the above

- 2) The Imaginary line of a turn extends out from the ground reference to the road you would be turning onto.

True
False

- 3) When should a bus driver full lock the steering wheel and begin a turn?
 - A. When the front bumper is on the imaginary line
 - B. When the rear tires clear the closest problem object
 - C. When the turning point intersects the imaginary line
 - D. None of the above

- 4) Turning points on school bus are the same as long as the turn is the same.

True
False

- 5) A turn is complete when all parts of the bus clear the closest problem object by
 - A. 12-36 inches
 - B. 18-36 inches
 - C. 12-18 inches
 - D. None of the Above

- 6) When steering around turns you should....
- A. Have your hands at approximately the 3 and 9 o'clock position
 - B. Not palm the steering wheel
 - C. Use the hand over hand method
 - D. do all of the above
- 7) When making a left turn you can apply the same concepts as making a right turn.
- True
- False
- 8) Activate the turn signal approximately _____ feet on approach of a turn.
- A. 100 feet
 - B. 200 feet
 - C. 50 feet
 - D. None of the above
- 9) It is not recommended to switch gears when making a turn
- True
- False
- 10) Tail swing becomes a major factor when making all type of turns.
- True
- False

Answer Key

1. B

2. True

3. C

4. False

5. A

6. D

7. True

8. A

9. True

10. True